

Design of a 3D-Printed Universal Wireless Charging Phone Stand

Hui Yang, Lin Zheng*, Zhijie Hu, Ziyou Li, Jingcheng Wang

College of Intelligent Manufacturing, Jingchu University of Technology, Jingmen, Hubei, China

*Corresponding Author

Abstract: To address the issues of limited functionality and insufficient scenario adaptability in traditional phone holders, this paper designs a universal wireless charging phone holder based on 3D printing technology. This product integrates multiple functions including clamping, universal adjustment, wireless charging, and sound enhancement. It features a self-adaptive clamping mechanism, a ball hinge adjustment structure, and a quick-release base, balancing stability and flexibility. Additionally, it uses a hollowed-out heat-dissipating phone cradle and a sound amplification cavity structure, facilitating heat dissipation and sound enhancement, thereby optimizing the user experience. Through SolidWorks modeling, model slicing parameter setting, and iteration, the optimal printing materials were selected for different structures, and the product was completed as an integrated print using the FDM process. Test results indicate that the product has a reliable structure, is easy to operate, adapts to multiple scenarios, effectively shortens the development cycle, and reduces costs, providing a reference for similar product development and demonstrating good application value.

Keywords: 3D Printing; Adaptive Clamping; Hollow Cooling; Quick Release

1. Introduction

Driven by the popularization of mobile electronics, smart phones serve as vital equipment for users' vehicle travel, work and household scenarios. Traditional phone stands with an integrated injection-molded design are fixed and relatively simple, offering limited functionality, which cannot meet users' diverse needs in different environments. Additionally, their fixed structure lacks both aesthetic appeal and practicality, making them inconvenient to use in certain situations. To address these issues, this paper designs a 3D-printed omnidirectional wireless charging phone stand. The phone stand

utilizes SolidWorks modeling and 3D printing technology to design and create the structures of product models. Afterward, the printed product components undergo post-processing and continuous iterative optimization. Finally, the assembly of the wireless charging phone stand and multi-scenario testing are completed. Through Solid Works modeling, the virtual form of the phone stand can be intuitively previewed, and multiple design iterations can be compared [1]. The core advantage of 3D printing technology is that it can directly convert a three-dimensional digital model into physical components without the need for additional mold design and manufacturing, significantly saving the time and cost of traditional mold development [2,3]. Additionally, relying on 3D printing technology allows for a comprehensive review of the structural compatibility within the production process [4,5], verification of the feasibility of design solutions [6], and targeted optimization of design details to select the most suitable implementation plan [7-9]. The combination of modeling technology and 3D printing processes enables product quality verification in the design phase [10-12], effectively shortens the overall project cycle, reduces unnecessary time waste and repetitive production, and achieves efficient coordination between design and manufacturing [13-15], and provide strong support for product innovation upgrades and rapid market deployment.

2. Model Building

This design combines a phone holder with wireless charging, continuously improving the structural design while fully considering the appearance. The appearance design balances aesthetics and heat dissipation functionality; the structural design includes the phone clamping area, the wireless charging area, the phone bracket area, the movable parts of the stand, and the base design, as shown in Figure 1, making it convenient to charge the phone when the battery is low in different scenarios. Due to the complex design added by the cable management groove,

3D design software is required for continuous optimization and improvement of the appearance.

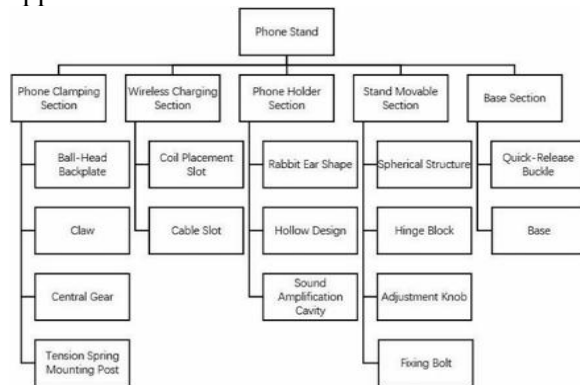

Figure 1. Overall Design Plan

2.1 Design of the Phone Clamping Section

To ensure the stability of the phone during the clamping process, the clamping device is composed of parts such as a ball-head backplate 1, claws 2, and a central gear 3. A standard spur gear is used as the central gear, and the two claws move back and forth through rack engagement with the central gear. Both the claws and the base plate have two tension spring mounting posts 4, so that when the phone is placed in position, it can be secured by the claws with the action of the tension springs. The inner sides of the claws are designed in a V-shape to prevent accidental pressing of the phone buttons during clamping. The clamping section is shown in Figure 2.

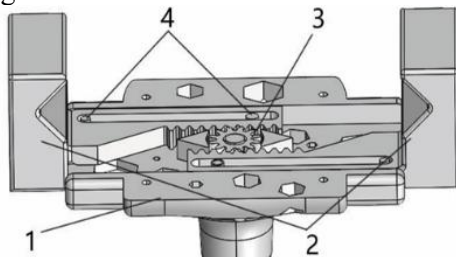

Figure 2. The Mobile Phone Clamping Part

2.2 Wireless Charging Area Design

To facilitate the use of wireless chargers and accommodate most wireless charging modules on the market, a coil placement slot with a diameter of 60mm is reserved inside the bracket to ensure a tight integration between the wireless charging coil and the bracket structure. At the same time, a cable slot is designed in the middle of the bracket for placing the charging cable, preventing the cable from getting tangled, as shown in Figure 3. This design perfectly integrates the wireless charging function with

the bracket, allowing users to simply place their phone on the bracket for automatic wireless charging, without the hassle of plugging and unplugging the charging cable, greatly enhancing convenience.

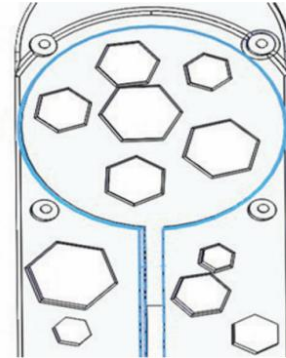

Figure 3. Phone Clamping Area

2.3 Phone Holder Design

In the design process of this product, the rabbit ear shape was combined with the phone stand, giving the product a unique appearance and increasing its fun and appeal. At the same time, because wireless chargers generate heat through coil induction during charging, prolonged close contact with the phone may cause it to overheat. Long-term high-temperature operation can reduce the battery life of the phone. Therefore, we designed the back of the stand with a hollow structure, which not only enhances heat dissipation but also reduces material weight. Additionally, an integrated sound cavity was designed at the bottom of the stand, with relatively smooth inner walls. Sound waves from the phone enter the cavity and reflect, interfering with the original sound waves, which increases sound intensity to some extent. It also allows the sound to be more focused in a specific direction, improving the efficiency and directionality of sound propagation. The stand component is shown in Figure 4.



Figure 4. Mobile Phone Holder Design

2.4 Design of the Movable Part of the Bracket

The product takes into account the different needs of users regarding the angle and fixation strength of the bracket. To accommodate multi-scenario and multi-angle adjustments, the movable part adopts a ball joint design. The mechanism features a spherical structure 2, which is tightened using a hinge block 3. To prevent the ball surface from slipping due to the weight of the phone, numerous uniformly distributed circular grooves are added to the sphere, further increasing the friction between the ball head and the hinge base. A bolt 4 is used in the middle to lock and secure it. By rotating the adjustment knob 1 on the side, users can adjust the angle between the ball head and the hinge base according to the actual usage scenario. The movable part of the bracket is shown in Figure 5.

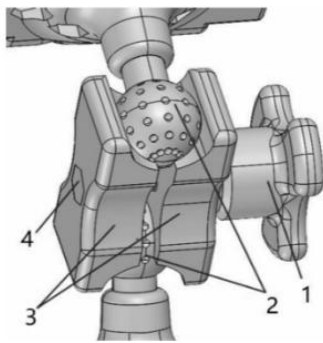

Figure 5. Design of the Movable Part of the Bracket

2.5 Base Design

To accommodate multi-scenario interactions, a snap-fit structure consisting of a buckle and a slot is provided at the connection between the base and the main body of the bracket, assisted by a spring plunger for additional fixation, as shown in Figure 6. When installing the base, the buckle is precisely inserted into the slot under the elastic pushing force of the spring plunger, forming a double locking effect that effectively prevents the connection from loosening due to shaking or displacement during use, ensuring the stability of the connection between the base and the main body. For disassembly, simply press the side release button, causing the plunger to retract and release the limitation on the buckle, allowing it to easily detach from the slot. This enables quick removal and replacement of the base, which can be flexibly adapted for various usage scenarios such as desktop placement, handheld portability, or wall mounting,

significantly enhancing the product's adaptability and operational flexibility. In order to meet the desktop usage scenario, a flat base with a length and width of 100mmX100mm is designed, as shown in Figure 7. The base is designed with a flat and wide rectangular structure, with a card slot designed in the middle, which can perfectly fit the buckle, as shown in Figure 7, which can realize the quick clamping and fixation of the main body and the base, and the assembly operation is simple and convenient, which is suitable for the use of daily desktop quick disassembly and assembly.

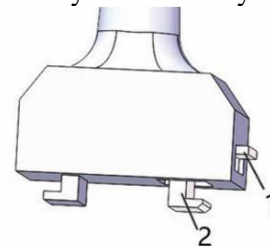

Figure 6. Base Fixed Buckle Design

2.6 Assembly

In SolidWorks, each design component is assembled, with precise positioning achieved through constraints such as co incidence, parallelism, and perpendicularity. The phone clamping component is placed at the top and connected to the ball hinge to secure it, while the bottom of the main bracket is clipped into the base to form an overall support structure. The components are assembled in order according to the upper and lower hierarchy, with the clamping end, the adjustable section of the ball hinge, and the clip support end connected pair by pair. All assembly constraints conform to actual force and motion requirements, ensuring both the structural stability of the assembly and the realistic operation logic of the ball hinge angle adjustment and clip engagement/disengagement, making the virtual assembly model consistent with the physical assembly. After the overall assembly is completed, the motion simulation module in SolidWorks can be used to check the rotation angle of the ball hinge and the engagement and disengagement stroke of the clip, verifying the smooth operation and assembly accuracy of all motion pairs. This ensures that the virtual assembly structure is consistent with the performance of the actual machined and assembled product, providing an accurate model basis for subsequent part machining and proto type testing. The completed assembly is shown in Figure 8.



Figure 7. Baseplate Design

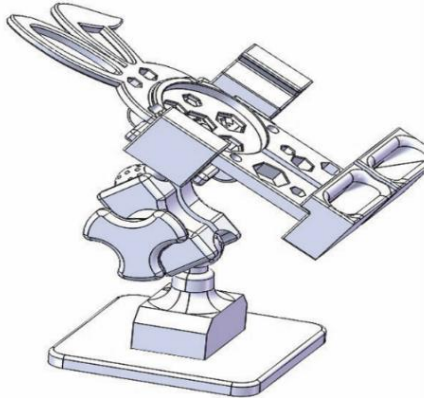

Figure 8. General Assembly Drawing

3. 3D Printed Physical Parts

3D printing abandons the design limitations of traditional assembly structures and can provide a more innovative design path for product development. The overall shell structure of the universal wireless charging mobile phone holder product developed this time is relatively complex, which is suitable for the design idea of integrated 3D printing. After the model design is completed, the model is exported as an STL universal format through SolidWorks, and then the STL format model is imported into slicing software to set and adjust the printing process parameters. Printing parameters have a direct impact on the molding quality of the finished product. The core parameters include printing material, infill density, etc. The specific printing parameters are shown in Table 1.

Table 1. Printing Parameters for Each Part

Part Name	Print Material	Infill Density
Ball-Head Backplate	PLA	50
Claw	PETG	30
Quick-Release Buckle	PLA	50
Lock Nut	ABS	60
Stand Backplate	PLA	20
Central Gear	PETG	60
Hinge Block	PLA	60
Flat Base	PETG	65

After printing, assemble all the parts to complete the production of this wireless charging phone stand, as shown in Figures 9 and 10.



Figure 9. Front View of the Phone Stand Model



Figure 10. Side View of the Phone Stand Model

4. Product Iteration Process

After the phone stand was completed, we randomly selected thirty prototype phones to test the clamping performance, mobility, and overall stability of the phone stand.

The specifications of the phones used by the thirty volunteers are shown in Table 2.

Table 2. Specifications of 30 Mobile Phones

Test No	Size	Weight	Test No	Size	Weight
1	6.1	175	16	6.4	189
2	6.7	168	17	6.67	206
3	6.1	197	18	6.7	182
4	6.7	159	19	6.8	173
5	4.7	170	20	6.78	185
6	6.82	217	21	6.78	184
7	6.7	178	22	6.8	231
8	6.7	175	23	6.59	202
9	6.7	174	24	6.78	194
10	6.36	168	25	6.59	202
11	6.73	166	26	6.59	206
12	6.7	174	27	5.55	185
13	6.67	169	28	6.39	194
14	6.2	204	29	6.72	104
15	6.8	218	30	6.8	180

Before the clamping test, the distance between the centers of the jaws could extend to a

maximum of 10cm and contract to a minimum of 6.5cm. The parameter that significantly affected the clamping force was the size of the phone. Among 30 phones, the smallest size was 5.55 inches, with a length of 15.7 cm and a width of 7.32cm; the largest was 6.82inches, with a length of 16.34cm and a width of 8.3cm. During the experiment, all 30phones could be successfully placed into the phone holder and clamped securely by the jaws. The phones did not fall, whether placed upright or upside down, making the clamping test successful. Subsequently, the mobility test was conducted, and the active part of the bracket was rotated 30 times while the mobile phone was clamped, and it was found that when the weight of the mobile phone was greater than200g, the active part of the bracket slipped slightly. To solve this problem, the adjustment knob on the side is adjusted to increase the friction between the ball hinges, but also to increase the lateral load of the mechanism. In the 22nd test, when the phone weighs 231g, after we further adjust the knob, the hinge out breaks, as shown in Figure 11. Therefore, we changed the printing parameters of the part, selected a stiffer ABS material, and increased the filling density to100 while redesigning the model to add many evenly distributed arc stripes on the spherical surface, further increasing the friction between the hinge and the sphere. The redesigned printed model can successfully pass 30 activity tests as shown in Figure 12, ensuring that all mobile phones can rotate without dead ends during the clamping process, and will not slip or break.



Figure 11. Broken Hinge Block



Figure 12. Redesigned Hinge Block

Finally, a comprehensive stability test was conducted. After clamping the phone, the stand

was placed flat on the table. By adjusting the angle of the stand's clamping part, the table was manually shaken to observe the stability of the stand at different angles. It was found that when the phone weighed less than 200g, the overall stability was good, and no collapse occurred during the shaking process. However, phones weighing more than 200g could tilt or collapse at certain angles. To address this issue, we increased the size of the base, changing it from the initial dimensions of 100mm x100mm to 150mmx150mm, switched the printing material to ABS, and set the infill density to 100. After the redesign, the experiment was repeated, and all 30 phones successfully passed the test.

5. Conclusion

To address the issues of traditional phone holders being single-function and poorly adaptable to different scenarios, a 3D-printed universal wireless charging phone stand was designed and manufactured. Modeling and virtual assembly were completed using SolidWorks, and materials such as PLA, PETG, and ABS were selected for different parts based on their functions, with different printing parameters set accordingly. After testing with 30 phones of various sizes and weights, and iteratively optimizing the materials, infill density, and dimensions of the hinge blocks and base, the product resolved problems such as slipping, breaking, and tipping over, meeting the requirements for clamping stability, mobility, and overall sturdiness.

Acknowledgments

This work was jointly supported by Horizontal Research Project of Jingchu University of Technology (Grant No. HZ26001), the Jingmen Science and Technology Think Tank Project (Grant No. 202621), College Student Innovation Training Program of Jingchu University of Technology (Grant No. S202511336057).

References

- [1] Barbero B R, Pedrosa C M. CAD learning in mechanical engineering at universities. *Computer-Aided Design and Applications*, 2020, 18(1): 24-41.
- [2] Shahrubudin N, Lee T C, Ramlan R J P M. An overview on 3D printing technology: Technological, materials, and applications. *Procedia Manufacturing*, 2019, 35:

- 1286-1296.
- [3] Silva A M, Costa J R, Mendes P S et al. CAD modeling and 3D printing optimization of lightweight mobile phone stands. *Journal of Manufacturing Processes*, 2022, 82: 568-581.
- [4] Zhang M H, Liu J F, Li Y L et al. Design and simulation of rack and pinion clamping mechanism for precision holding de vices. *Mechanism and Machine Theory*, 2021, 160: 104052.
- [5] Wang X G, Zhao L N, Jiang H B et al. Integrated structural de sign of wireless charging module and portable electronic support. *Journal of Electronic Packaging*, 2022, 144(2): 021008.
- [6] Mishra S K, Sahoo A K, Pradhan S et al. FDM 3D printing of PLA phone stands: CAD design and mechanical performance analysis. *Materials Today: Proceedings*, 2023, 76: 1092-1098.
- [7] Kim J H, Park S Y, Lee J W et al. Multi-material 3D printing of ergonomic phone stands with integrated CAD modeling. *Journal of Materials Processing Technology*, 2024, 329: 117762.
- [8] Lopez R, Martinez C, Sanchez F et al. CAD-based topological optimization for 3D printed lightweight phone stands. *Structures*, 2021, 33: 2018-2030.
- [9] Lee S H, Cho Y J, Kim B G et al. Design validation of 3D printed phone brackets via CAD simulation and experimental testing. *Procedia Manufacturing*, 2019, 41: 789-798.
- [10]Rodriguez M, Gonzalez J, Fernandez L et al. Finite element analysis and 3D printing of ABS plastic phone stands via CAD customization. *Computer-Aided Design and Applications*, 2021, 19(3): 452-465.
- [11]Dey A, Yodo N. A systematic survey of FDM process parameter optimization and their influence on part characteristics. *Journal of Manufacturing and Materials Processing*, 2019, 3(3): 64.
- [12]Patel N K, Shah D K, Trivedi M J et al. A study on FDM 3D printing parameters for CAD-designed mobile phone support brackets. *Procedia Engineering*, 2020, 288: 1214-1221.
- [13]Garcia J, Ruiz M, Ortiz J et al. Parametric CAD design for mass customization of 3D printed mobile phone holders. *Robotics and Computer-Integrated Manufacturing*, 2022, 76: 102235.
- [14]Wang X, Li Z, Liu Q et al. Integration of CAD/CAM and 3D printing for the fabrication of anti-slip phone stands. *Journal of Advanced Manufacturing Technology*, 2024, 135(56): 1899-1912.
- [15]Gupta S, Sharma A, Malhotra R et al. Cost and time optimization of 3D printed phone holders from CAD digital models *Measurement*, 2022, 195: 111128.